

2

1

B

B

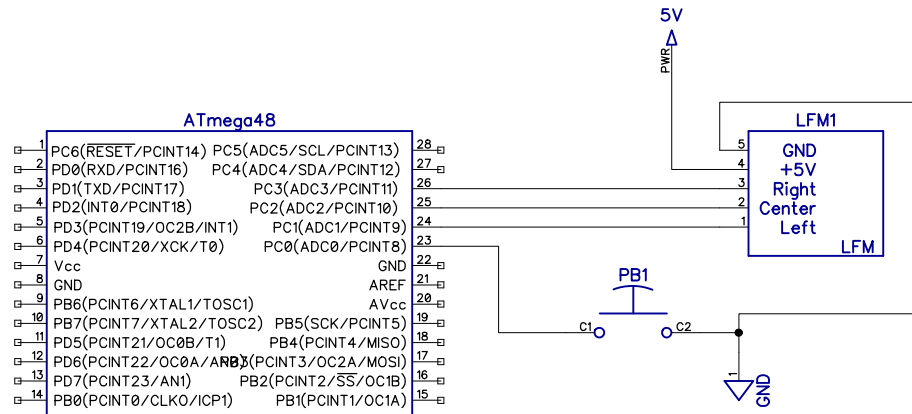

1. The ATmega48 is on the Chibot controller. Please review the Chibot controller schematic.
2. Please see the Line Following Module schematic for details on LFM1
3. Port C0 needs its internal pull-up resistor activated.

A

A

Bucketworks 1340 North 6th Street Milwaukee WI 53122	BarCampMilwaukee3 Line Following Robot kit		
	BarCampMilwaukee3		
	SIZE	FSCM NO.	DWG NO. BCM3Bot.dch
	SCALE		REV 1
			Sheet 1

2

1