

Assembly

And

Operation

Of the

DevBoard-M32

Controller

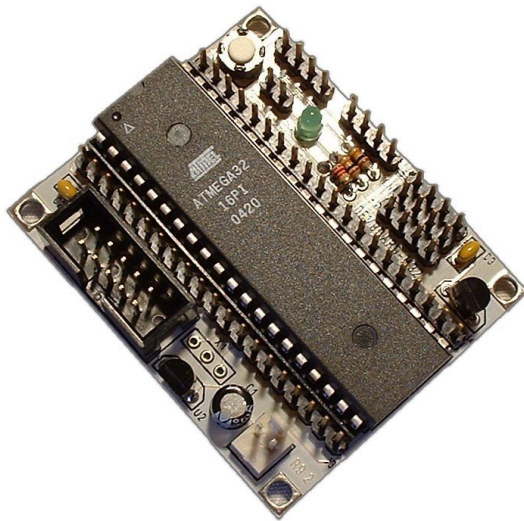

Table of Contents

Introduction	1
Parts List	1
Assembly Notes	5
Soldering Notes	6
Step-By-Step Assembly	7
Initial Tests	10
Operation	10
In Case of Difficulty	11
Specifications	11
Circuit Description	11
ATMega32 Pin-out Worksheet	12
Programming the M32	13
Original M32 Fuse Settings	14
Enabling External Resonator	14
M32 Controller Connectors	15
Warranty	15
Customer Service	15
Schematic	16
Contact Information	17

INTRODUCTION

The DevBoard-M32 Controller is a versatile, easy-to-use, general-purpose controller using the popular Atmel ATmega32 microcontroller. The board includes no more than is absolutely necessary for a basic controller, thus keeping the cost and board size to a minimum. All of the individual pins have been brought out to standard .1"-spaced headers to accommodate interfacing to almost any kind of circuitry.

It is designed for use in applications ranging from robotics to industrial controller applications.

The following features make M32 very versatile:

- Operates over a wide range of supply voltage: 7 to 15 Volts
- On-Board Power Distribution Bus
- On-Board Reset Switch
- Standard ISP Connector for "In-System-Programming"
- On-Board Power Indicator LED
- On-Board Regulation for the Microcontroller
- Separate On-Board Regulation for the Power Distribution Bus
- Two On-Board TWI* Connectors
- On-Board TWI Pull-up Resistors
- Optional Ceramic Resonator Connection for Accurate Clock Frequency up to 16 MHz
- User-Selectable TWI Clock and Data Lines

NOTE: If you purchased an assembled M32, you can skip over the assembly instructions.

**TWI is compatible with I²C*

PARTS LIST

Check each part against the following list. Make a check in the space provided (✓) as you identify each part. The parts may vary slightly from the picture. Any part that is individually packaged with a part number on it should be kept in its package after it is identified until you use it. Save all packaging material until all parts have been located.

To order a replacement part, contact the seller of this kit and indicate the model, value, and a description of the part to be replaced.

Each circuit part in this kit has its own circuit component number (R2, C1, etc.). Use these numbers when you want to positively identify the same part in the various sections of the Manual. These numbers, which are especially useful when a part has to be replaced, appear:

- In the Parts List,
- At the beginning of each step where a component is installed,
- In the schematic,
- In the sections at the rear of the Manual.

<u>KEY</u>	<u>QTY</u>	<u>DESCRIPTION</u>	<u>CIRCUIT #</u>
------------	------------	--------------------	------------------

RESISTORS – Note: The following resistors are 1/8 watt

A1 ()	2	10 kΩ(brown-black-orange)	R1, R2
A1 ()	1	2200 Ω (red-red-red)	R3

KEY	QTY	DESCRIPTION	CIRCUIT #
-----	-----	-------------	-----------

CAPACITORS

A2 ()	1	10 μ F 50 Volt	C1
A3 ()	2	.1 μ F Monolithic Ceramic	C2, C3

DIODES-LIGHT EMITTING DIODES

B1 ()	1	Green T-1 LED	D1
--------	---	---------------	----

INTEGRATED CIRCUITS

C1 ()	1	AT Mega 32	U1
C2 ()	2	78L05	U2, U3

SOCKETS-CONNECTORS

D1 ()	1	40-Pin IC Socket
D2 ()	1	2-Pin Power Header
D3 ()	1	10-Pin ISP Header
D4 ()	7	Straight Pin Headers, 2 20-pin & 5 4-pin
D5 ()	1	2-Pin Straight Pin Header
D6 ()	1	Battery 2-Pin Socket
D7 ()	1	Battery Snap Connector

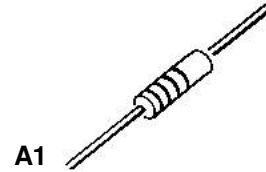

MISCELLANEOUS

E1 ()	1	Reset Switch
E2 ()	1	Circuit Board

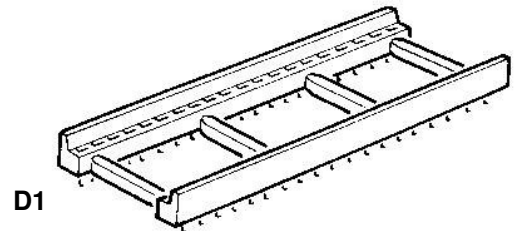
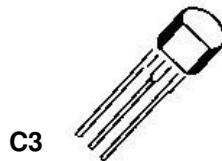
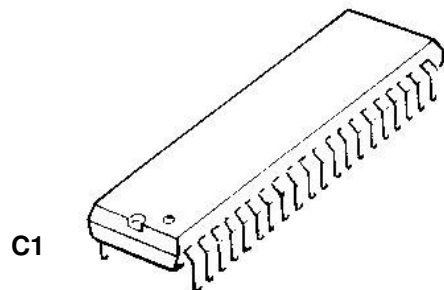
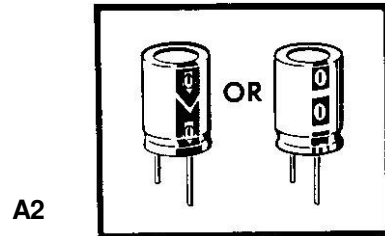
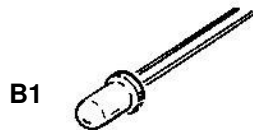
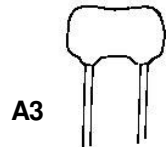

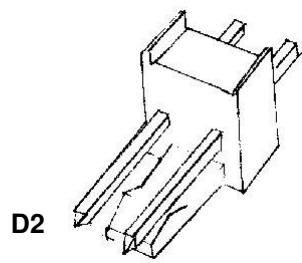

D2

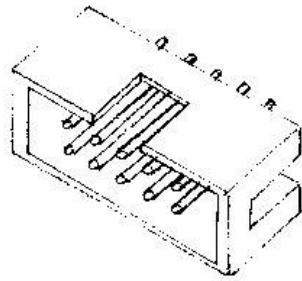

D3

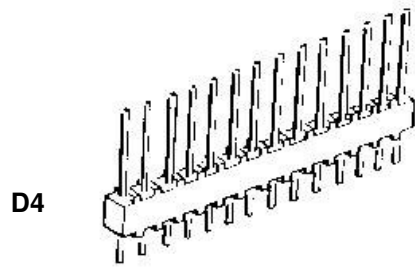

D4

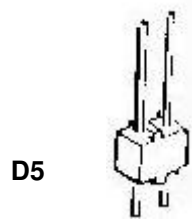

D5

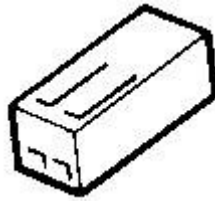

D6

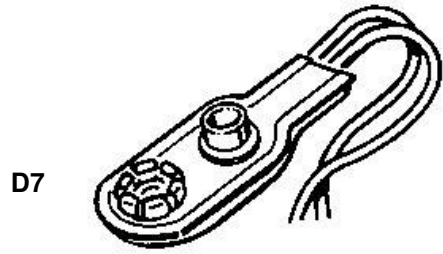

D7

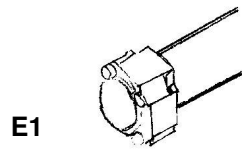

E1

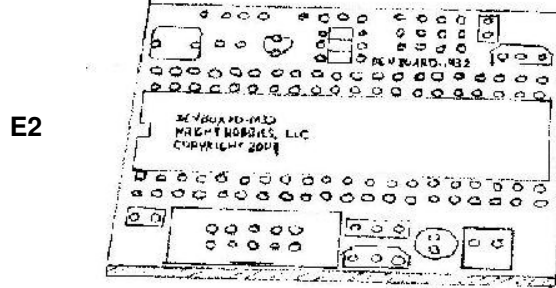

E2

ASSEMBLY NOTES

The illustrations in this Manual are called Pictorials and Details. Pictorials show you the result of performing a group of assembly steps. Details generally show how to perform a single step. When you are directed to refer to a certain Pictorial “for the following steps,” continue using that Pictorial until you are referred to another Pictorial for another group of steps.

Read the entire step before you perform the operation; then follow the instructions carefully. Position all parts as shown in the Pictorials.

Install the components on the component (lettered) side of the circuit board in the circuit board Pictorials and then solder the leads to the foil side. Resistors are designated by their resistance value in Ω (ohms), $k\Omega$ (kilohms), or $M\Omega$ (megohms) and color code. Capacitors will be designated by their capacitance value (in pF and μF) and type (disc, tantalum, or electrolytic). Position all electrolytic and tantalum capacitors only as shown.

Due to the small foil area around the circuit board holes and the small areas between foils, use the utmost care to prevent solder bridges between adjacent foil areas. Use only a minimum amount of solder and use no larger than a 40-watt soldering iron with a small tip. Allow it to reach operating temperature, and then apply it only long enough to make a good solder connection.

Wipe the soldering iron tip often on a damp cloth or sponge. It is a good habit to wipe the iron each time you solder a group of connections. The soldering tip must be clean of oxidation and have a bright thin solder coat.

SAFETY WARNING: Avoid eye injury when you cut off excess lead lengths. Hold the leads so they cannot fly toward your face or eyes, and be sure to wear protective eye gear.

SOLDERING NOTES

A GOOD SOLDER CONNECTION

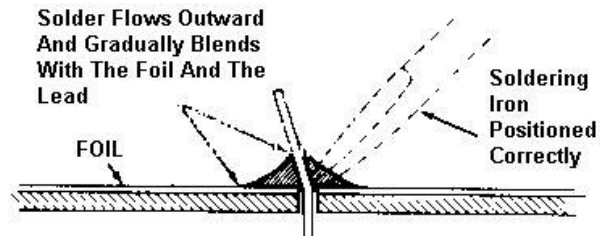

POOR SOLDER CONNECTIONS

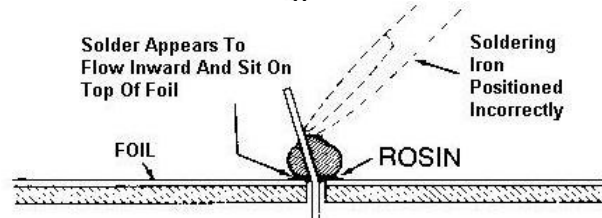
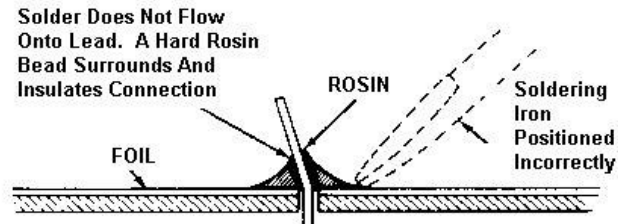

SOLDER BRIDGES

A Solder bridge between two adjacent foils is shown in photograph A. Photograph B shows how the connection should appear. A solder bridge may occur if you accidentally touch an adjacent previously soldered connection, if you use too much solder, or if you “drag” the soldering iron across other foils as you remove it from the connection. A good rule to follow is: always take a good look at the foil area around each lead before you solder it. Then, when you solder the connection, make sure the solder remains in this area and does not bridge to another foil. This is especially important when the foils are small and close together. NOTE: It is all right for solder to bridge two connections on the same foil.

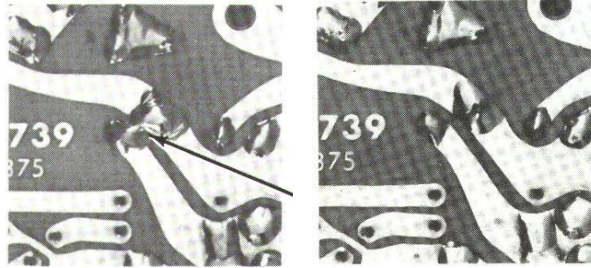

Use only enough solder to make a good connection, and lift the soldering iron straight up from the circuit board. If a solder bridge should develop, turn the circuit board foil side down and heat the solder between the connections. The excess solder will run onto the tip of the soldering iron, and this will remove the solder bridge. NOTE: The foil side of most circuit boards has a coating on it called “solder resist.” This is a protective insulation to help prevent solder bridges.

STEP-BY-STEP ASSEMBLY

() R1: 10 k Ω (brown-black-orange)

() R2: 10 k Ω (brown-black-orange)

() R3: 2.2 k Ω (red-red-red)

() Solder the leads to the foil and cut off the excess lead lengths.

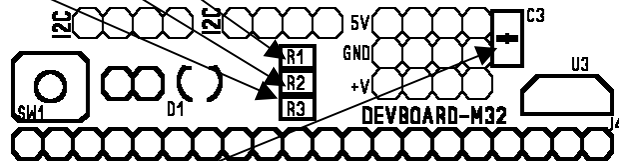

() C3: .1 μ F Monolithic Ceramic Cap

() C2: .1 μ F Monolithic Ceramic Cap

() C1: 10 μ F Electrolytic Cap
 Be certain to observe the polarity
 Of the capacitor with the plus lead
 (+) installed in the corresponding
 hole.

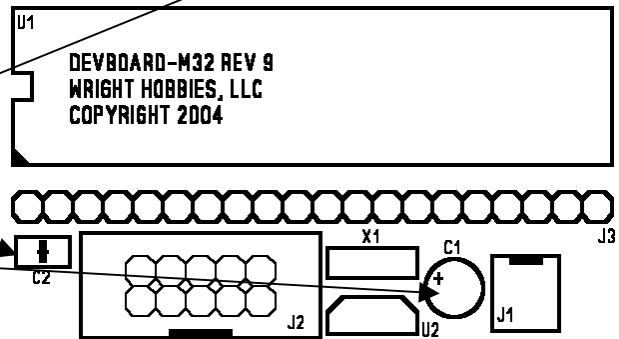

() Solder the leads to the foil and cut off the excess lead lengths.

() Set the board aside for a moment while you prepare the pin connectors for installation.

Note - In the following steps it may be easier to insert the pin headers then turn the board over, allowing it to rest on top of the pins before soldering. This will hold the pins in place, making it easier to solder.

- () Insert and solder the 40 pin IC socket at U1. Make sure that the pin 1 orientation matches the outline on the PC board.

- () Insert and solder the 20 pin headers.

- () Insert and solder the 5 4-pin headers.

- () Insert and solder the 2-pin header.

- () Insert and solder the reset switch. Trim the excess lead length.

- () Insert and solder the 2 5-Volt regulators (78L05) using the detail below. Trim the excess lead length. The flat side of the regulator should face downward, matching the flat side of the outline.

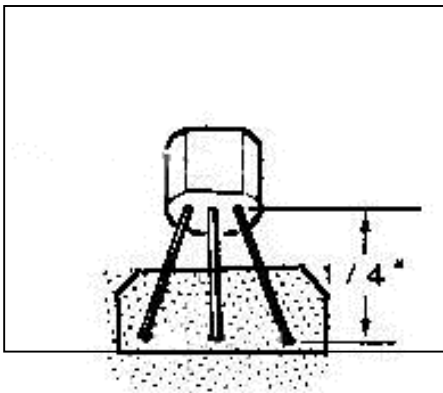

- () Insert and solder the Power connector at J1. Be sure that the polarity tab is placed at the top of the box where the outline shows it.

- () Insert and solder the 10-pin ISP connector. Again, make certain that the polarity slot is downward as indicated by the outline on the PC board.

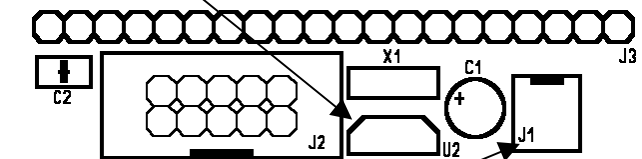
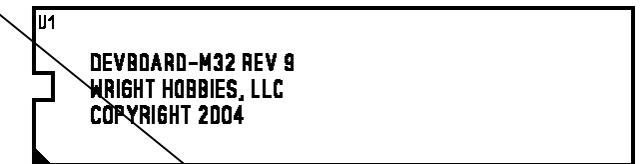
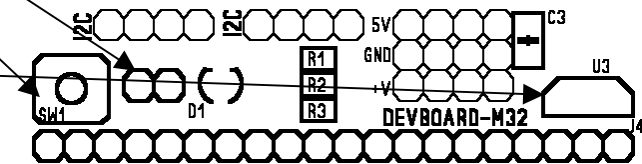
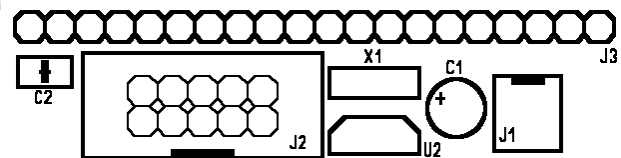
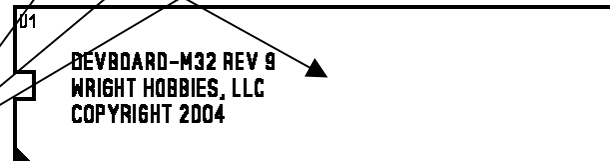
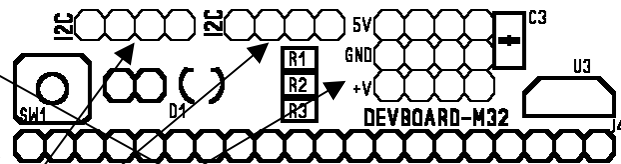

- () Install and solder the LED using the detail below. Trim the excess lead length.

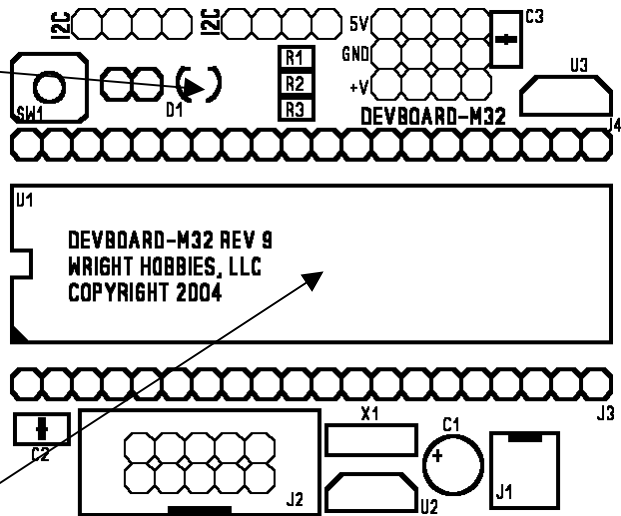
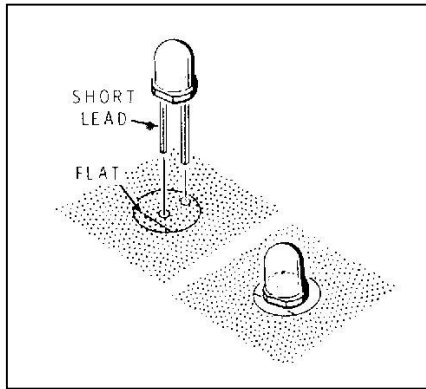

- () Carefully remove the Atmel AT Mega 32 from the plastic tubing and insert it into the 40 pin socket with pin 1 oriented as per the the outline. You may need to straighten the pins, but do not handle any more than necessary.

This completes the assembly of the M32 controller board.

Check all solder connections on the solder side of the board. Make certain that there are no bridged solder connections.

INITIAL TESTS

Connect the battery connector to the M32 controller board and attach it to a 9 Volt battery. You should see the LED light. If not, then remove the battery immediately and proceed to the “In Case of Difficulty” section.

The M32 is shipped with a program installed that will increment each of the ports from 0 to 255 and then start over again. When the M32 is first powered up, you should see the port pins on each port increment in binary.

To remove this program, simply erase the Flash memory area using one of the many software tools available for the Atmel AVR series of microprocessors.

OPERATION

The M32 controller board is intended for use with almost any of the AVR programming tools available. We recommend Bascom AVR, available from MCS Electronics. This software is available in a “demo” version that limits the output to 2k of compiled code. This is more than enough to test and demo the M32. Since the M32 can handle up to 32k of compiled code, you should consider purchasing the full version. It is available from Wright Hobbies at <http://www.wrighthobbies.net/catalog>.

WinAVR is a set of tools released under the GNU GPL license that comprise a C development suite for AVR microcontrollers. The install is available at: <http://sourceforge.net/projects/winavr/>

Of course you can always download the AVR Studio from Atmel directly. This software is free and allows you to program, simulate, download and run your software written in the AVR assembly language. You will find the AVR Studio at <http://www.Atmel.com>

The ISP (In System Programmer) connection is compatible with most programmers using the standard 10-Pin ISP interface. This is found on the STK200/300/500, and several other programmers available today. You can also purchase our optional ISP Programmer that is also compatible with all of our microcontroller boards.

IN CASE OF DIFFICULTY

<u>Problem</u>	<u>Check</u>
LED will not light	Battery is properly connected Battery is providing at least 7 volts (dead battery) 78L05 Regulator is producing 5v
Port Pins not changing	Poor solder connections on the 40-pin DIP socket or the 20-pin headers ATMega32 chip is installed correctly Program has been changed or erased from the ATMega32 Fusebits have been changed in the ATMega32

SPECIFICATIONS

- 32k bytes programmable flash
- 2k bytes SRAM
- 1k bytes EEPROM
- 8 MHz operation (16mhz optional)
- Up to 8 MIPS
- 32 I/O pins
- 8 ADC Channels
- 4 PWM Channels
- 2 8-bit timers/counters
- 1 16-bit timer/counter
- 1 hardware serial UART
- SPI master/slave
- Power consumption ~ 20 mA

CIRCUIT DESCRIPTION

The heart of the M32 Controller board is the Atmel ATMega32 microcontroller chip. The board provides a regulated 5V power supply from the power connector. The board also provides an additional separate regulated 5V power supply intended for peripherals and any other “off-board” modules. The raw power input is also available on the power distribution bus and can be used for any peripherals that do not require a regulated 5 Volt supply. The ISP connector utilizes the ISP pins of the ATMega32 in the industry standard pin-out. TWI connections are located on the board and provide individual pull-up resistors for the SCL and SDA lines. These are not directly connected to the ATMega32 chip, but are brought out to two additional pins for optional connection to pins 22 and 23 of the ATMega32 chip. The TWI pins provide Ground, + 5 Volts, and the SCL and SDA lines. A momentary reset switch has been connected directly to pin 9 of the ATMega32 chip.

Please see the Atmel ATMega32 Datasheet for additional details on programming and operation of the ATMega32 chip.

M32 PIN-OUT WORKSHEET

The M32 Pin-out Worksheet is very handy for identifying the various pins used on the M32 with your own names. These can then be the same names that are referenced in your software program for the M32. Make a few copies of this page for future use.

<u> </u> PB0	1		40	<u> </u> PA0
<u> </u> PB1	2		39	<u> </u> PA1
<u> </u> PB2	3		38	<u> </u> PA2
<u> </u> PB3	4		37	<u> </u> PA3
<u> </u> PB4	5		36	<u> </u> PA4
<u> </u> PB5	6		35	<u> </u> PA5
<u> </u> PB6	7		34	<u> </u> PA6
<u> </u> PB7	8		33	<u> </u> PA7
<u> </u> RST	9		32	<u> </u> AREF
<u> </u> VCC	10		31	<u> </u> GND
<u> </u> GND	11		30	<u> </u> AVCC
<u> </u> XTL2	12		29	<u> </u> PC7
<u> </u> XTL1	13		28	<u> </u> PC6
<u> </u> PD0	14		27	<u> </u> PC5
<u> </u> PD1	15		26	<u> </u> PC4
<u> </u> PD2	16		25	<u> </u> PC3
<u> </u> PD3	17		24	<u> </u> PC2
<u> </u> PD4	18		23	<u> </u> PC1
<u> </u> PD5	19		22	<u> </u> PC0
<u> </u> PD6	20		21	<u> </u> PD7

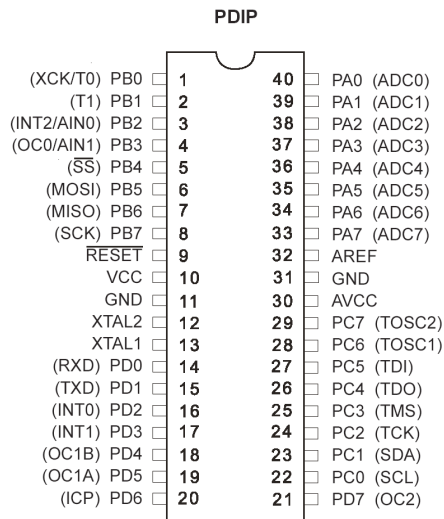

M32 CONNECTIONS

The M32 has several connectors used for different purposes. Below is a diagram defining the pin outs of the various connectors:

- J1 – Battery/Power Connector
- J2 – In-System Programming Connector
- J3 – MCU Pin Header, Pins 1-20
- J4 – MCU Pin Header, Pins 21-40
- TWI – Dual 4-pin headers for TWI Devices
- SCL/SDA – Clock & Data pins for TWI headers (user selectable)
- Power Bus – 4 rows of 3 pins for unregulated power, ground and regulated power

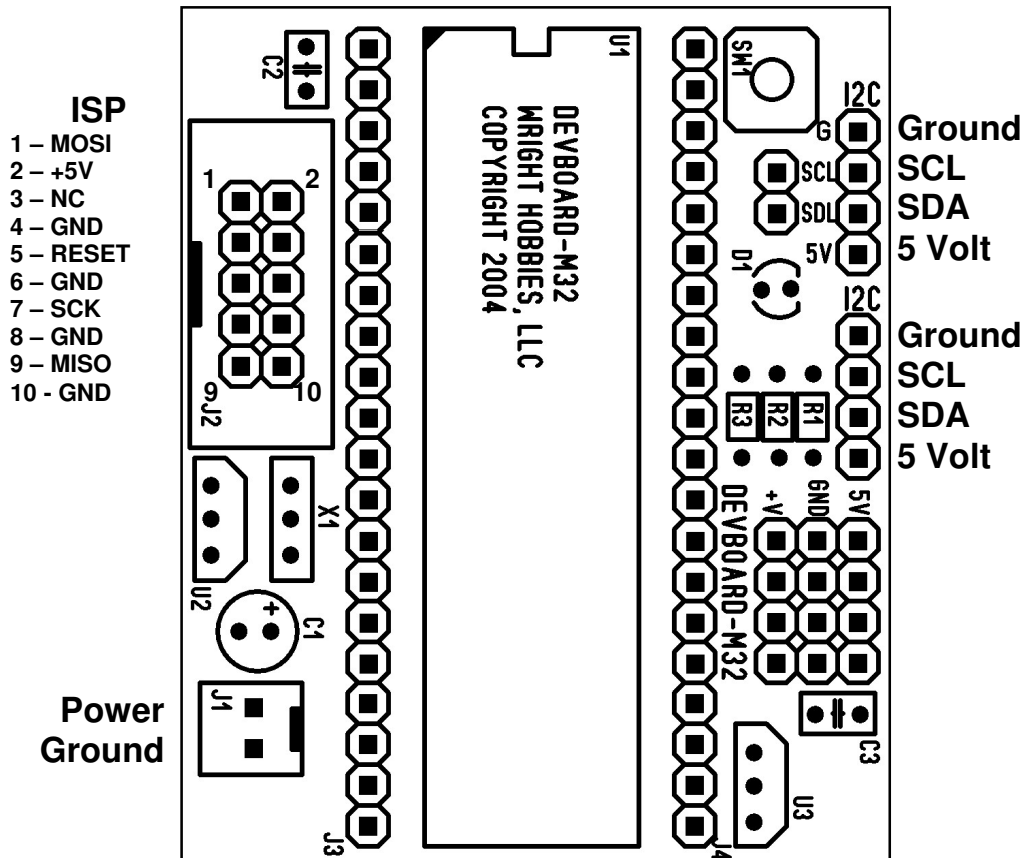

Note: The SCL & SDA lines of the TWI connectors need to be connected to 2 pins of the MCU. You can use the hardware-supported pins (22 & 23) or select any 2 pins as supported by your software.

PROGRAMMING THE M32

The following steps assume that you have installed Bascom. If you are using a different compiler, follow the directions given with that compiler.

To test the device, launch Bascom, click on Options/Programmer and select the STK200/STK300 Programmer from the drop-down list – You only need to do this once. Next, select Options/Compiler/Chip and select the M32 from the drop-down list, then click OK. Now type in the following program that will flash an LED connected to PB0 on the M32:

```
'Simple Demonstration Program for the M32 Controller

Config Portb = Output          'Set the Port B pins to output

Do
  Toggle Portb.0              'Create a loop
  Wait 1                       'Toggle PB0 High/Low (Port B, bit 0)
Loop                           'Wait 1 Second
                               'Repeat

End
```

Compile the program by selecting Program/Compile or by pressing the F7 key. If no errors occur, load the program into the M32 by selecting Program/Send to Chip or by pressing F4. A dialog box similar to Figure 1 should appear. Notice that it has identified the chip as an M32.

To load the program into the chip, select Chip/Autoprogram. This loads the compiled program into the chip and verifies that it loaded properly.

Now you are ready to wire up the test circuit as in Figure 2. Using a breadboard, connect PB0 (refer to the M32 PINOUT WORKSHEET) to a 1k resistor. Connect the other end of the resistor to the anode of an LED. Then connect the cathode end of the LED to a ground pin on the M32. The LED should now flash on and off slowly. If it doesn't, try reversing the polarity of the LED.

Note: This example uses stranded wire with crimp on connectors. Read the section “M32 CONTROLLER CONNECTORS” for more information on what hardware to use to connect wires to the M32.

You can find other programming samples on our web site: <http://www.wrightobbies.net>.

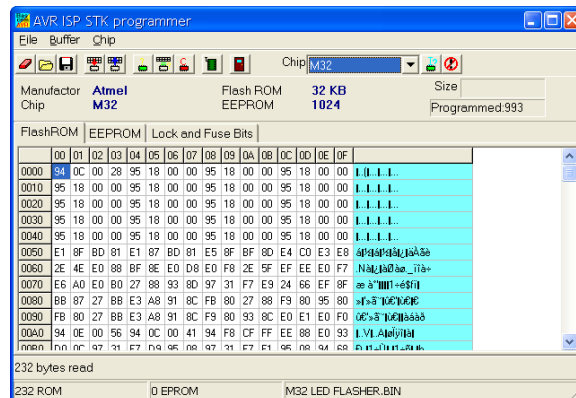
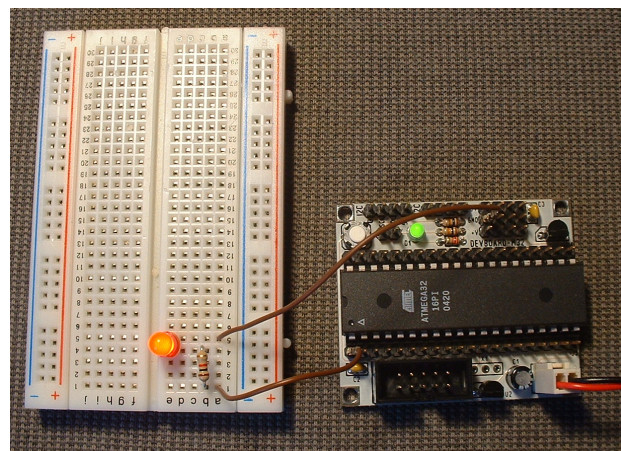

Figure 1 - Bascom Internal Programmer



DEFAULT M32 FUSE SETTINGS (These are **not** the defaults from Atmel)

Please note that if you re-program some of the various “fuses” in the M32, this can cause the microcontroller to become non-responsive. Use extreme care and read the datasheet carefully before changing any of the ATmega32 fuse bits. If your microcontroller becomes non-responsive, you will need to use a “parallel” programmer (such as the STK-500 from Atmel) to set the fuses back to their original configuration.

The fusebits of the ATmega32 control various aspects of the microcontroller. For most, the default settings do not need to be changed. For advanced users, the fusebits can be changed to allow for higher speeds using an external ceramic resonator. Table 1 below shows the default M32 fusebit settings (not the factory defaults). Table 2 shows the settings for using an external ceramic resonator up to 16mhz.

The fusebits are changed using the Bascom built-in programmer.

Warning - If you do not understand how to change the fusebits then do not attempt to make any changes!

Fusebits	
Fusebit C	0:BODLEVEL 4.0V
Fusebit B	1:BODEN disabled
Fusebit KL	00:6CK, BOD enabled
Fusebit A987	0100:Internal RC oscillator 8 MHz

Fusebits High	
Fusebit I	1:OC DEN fuse unprogrammed
Fusebit H	1:JTAG disabled
Fusebit Q	0:Serial programming enabled
Fusebit P	1:osc. options not programmed
Fusebit G	1:Erase EEPROM when chip erase
Fusebit FE	00:2048 words boot size
Fusebit D	1:Reset vector is \$0000

Table 1 - Default M32 Settings

Fusebits	
Fusebit C	0:BODLEVEL 4.0V
Fusebit B	1:BODEN disabled
Fusebit KL	00:6CK, BOD enabled
Fusebit A987	1110: Ceramic Resonator/Crystal, fast rising power

Fusebits High	
Fusebit I	1:OC DEN fuse unprogrammed
Fusebit H	1:JTAG disabled
Fusebit Q	0:Serial programming enabled
Fusebit P	0:osc. options programmed
Fusebit G	1:Erase EEPROM when chip erase
Fusebit FE	00:2048 words boot size
Fusebit D	1:Reset vector is \$0000

Table 2 – External Resonator Settings

ENABLING EXTERNAL RESONATOR

An external ceramic resonator can be added to the M32. This allows for higher speeds up to 16mhz and better accuracy. A standard 3-pin ceramic resonator can be soldered into the 3-holes indicated as X1 on the M32. Once this is soldered into place, change the fusebit settings as indicated in Table 2 and save the fusebits & fusebits high.

Remember to change the frequency setting in Options/Compiler/Communications in Bascom to match the frequency of the resonator you installed. This is important for any timing and communications routines in Bascom.

M32 CONTROLLER CONNECTORS

The M32 is designed to use .025" square pin MT header connectors and housings to make both I/O and power connections. These are available at <http://www.wrighthobbies.net/catalog>.

TIPS:

- A crimping tool is recommended but not required - you can use needle nose pliers to crimp the connector. For an even better connection, can solder the wire to the MT connector. Be careful not to use too much solder!
- Use stranded wire with these connectors. Cat-5 stranded wire works well and is easy to find. 24-28 gauge is recommended
- With smaller wire, fold the bare wire down against insulation and crimp both wire and insulation together. Otherwise, smaller gauge wire may pull out of the crimped connector
- Wires with MT connectors create reusable jumpers that you can use with a variety of applications. You can also connect them to a breadboard by purchasing MT male headers that will insert into the connector and the breadboard

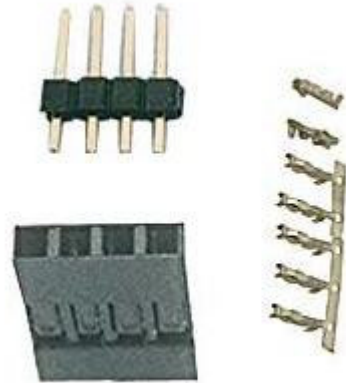

WARRANTY

The M32 Controller is guaranteed to be free from defects for a period of one year from the date of purchase. Due to the nature of this prototyping item, this warranty does not cover any damage to the Atmel ATmega32 due to overload, over-voltage or static damage to any of the I/O pins. Read the Atmel datasheet carefully and be sure to keep within all maximum parameters of the device.

CUSTOMER SERVICE

If you find that your M32 is no longer functional, return it to the vendor and it will be completely repaired for a nominal shipping and handling fee.

M32 CONTROLLER SCHEMATIC

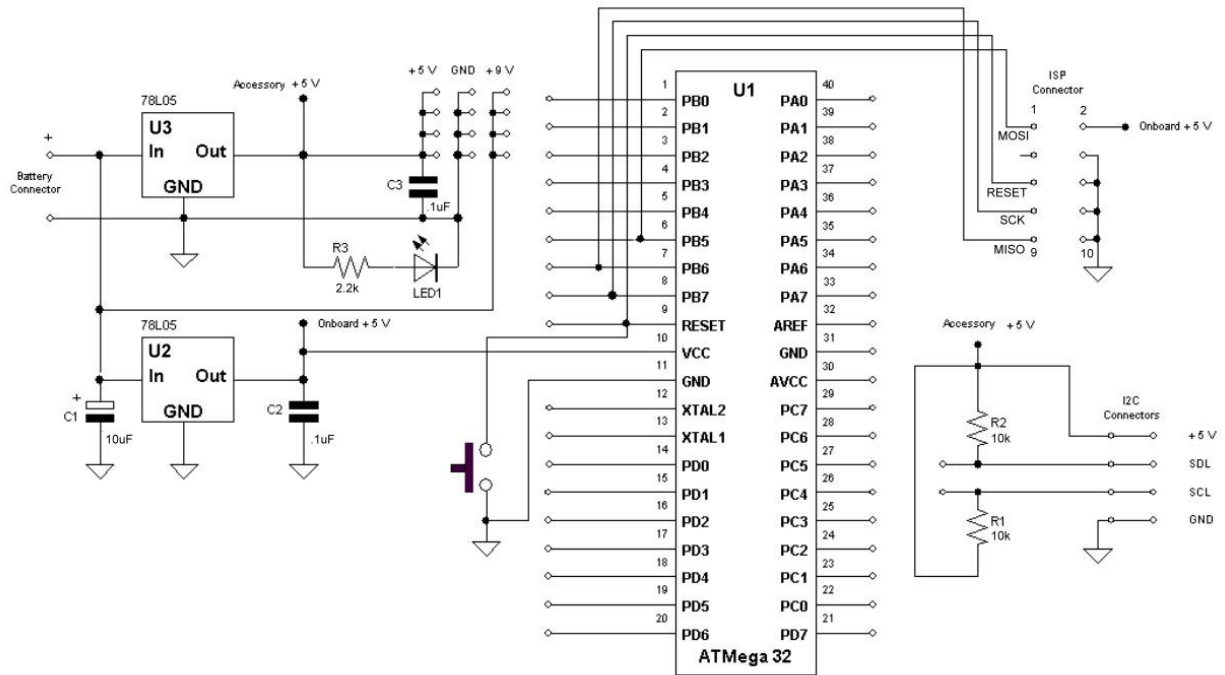

CONTACT INFORMATION

Wright Hobbies, LLC
627 N Ashbury Ave
Bolingbrook, IL 60440

Website: <http://www.wrighthobbies.net>
Support: support@wrighthobbies.net
Telephone: 630-214-9534